

JOB:	
ORDER REVISION:	
WIN:	

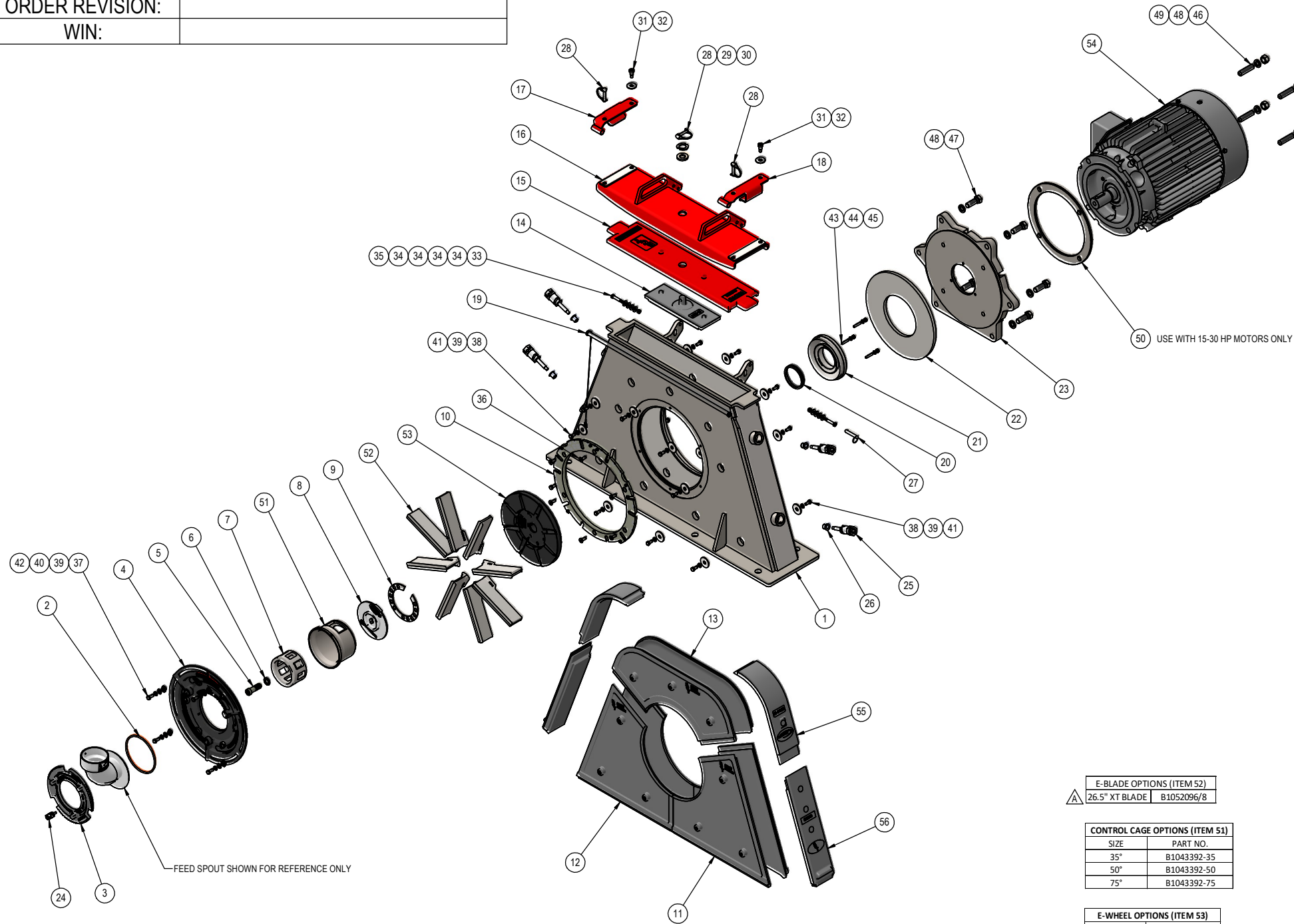

E-BLADE OPTIONS (ITEM 52)

26.5" XT BLADE	B1052096/8
----------------	------------

CONTROL CAGE OPTIONS (ITEM 51)

SIZE	PART NO.
35"	B1043392-35
50"	B1043392-50
75"	B1043392-75

E-WHEEL OPTIONS (ITEM 53)

MOTOR HP	PART NO.
15	M-2097-e-15-30
20	
25	
30	
40	M-2097-e-40-50
50	
60	M-2097-e-60-75
75	

END LINER OPTIONS (ITEMS 55 & 56)

OAL	P/N COMBINATION
31"	M-3682 (1) (TOP) & M-3683 (1) (BOTTOM)
32"	M-3682 (1) (TOP) & B30484 (1) (BOTTOM)

FEED SPOUT OPTIONS

FEED SPOUT ANGLE	PART NO.
90°, 3.00" HOSE	B17886
90°, 3.50" HOSE	B22384
45°, 3.00" HOSE	B19184
45°, 3.50" HOSE	B19185
0°, 3.00" HOSE	B19186
0°, 3.50" HOSE	B19187

MOTOR SPACER RING OPTIONS (ITEM 50)

MOTOR HP	PART NO.
15-30 HP	M-2587 (DWG 11-1985-A)
40-75 HP	NO SPACER REQUIRED

MOTOR OPTIONS (ITEM 54)

DESCRIPTION	PART NO.	WEIGHT
15 HP - 1800 RPM	M-1800-15-PE	280
	M-1800-15-XT	353
20 HP - 1800 RPM	M-1800-20-PE	295
	M-1800-20-XT	353
25HP - 1800 RPM	M-1800-25-PE	415
	M-1800-25-XT	399
30 HP - 1800 RPM	M-1800-30-PE	450
	M-1800-30-XT	399
40 HP - 1800 RPM	M-1800-40-PE	486
	M-1800-40-XT	772
50 HP - 1800 RPM	M-1800-50-PE	753
	M-1800-50-XT	772
60 HP - 1800 RPM	M-1800-60-PE	1022
	M-1800-60-XT	1094
75 HP - 1800 RPM	M-1800-75-PE	1045
	M-1800-75-XT	1094

NOTE: SEE SALES ORDER FOR SPECIFIC MOTOR CONFIGURATION.

ITEM	WEIGHT	QTY.	DESCRIPTION	PART	DRAWING
1	412.35	1	M4 FABRICATED HOUSING	M-3757	12-3026-D
2	0.03	1	FEED SPOUT SEAL RING, TWISTLOK	B17918	B17918
3	4.94	1	TWISTLOK RING	B17863	B17863
4	34.97	1	CONTROL CAGE ADAPTER ASSY, TWISTLOK, EXTREME DUTY	B1044051	B1044051
5	0.33	1	IMPELLER BOLT	B12809	B12809
6	0.02	1	WASHER, WEDGE LOCK, .750, ZINC PLATED	MH-2373	-
7	5.09	1	IMPELLER, TWISTLOK, 2.5 WIDE	B1043393	B1043393
8	3.35	1	WEAR PLATE, NUCKLESAVER, TWISTLOK	B17873	B17873
9	0.39	1	INDEX RING, NUCKLESAVER	B17866	B17866
10	11.35	1	T-NUT RING, TWISTLOK	B17875-N	B17875
11	33.22	2	CAST SIDE LINER BOTTOM RIGHT, THREADED, M4	B25199	B25199
12	32.51	2	CAST SIDE LINER BOTTOM LEFT, THREADED, M4	B25200	B25200
13	26.50	2	CAST SIDE LINER TOP, THREADED, M4	B25201	B25201
14	12.92	1	TOPLINER M4	M-3681	11-2953-B
15	3.84	1	SEAL, M4 LID	B11768	B11768
16	26.47	1	M4 LID WELDMENT	M-3656	11-2930-B
17	1.61	1	LID SWIVEL CLAMP LH	M-3474	11-2443-B
18	1.61	1	LID SWIVEL CLAMP RH	M-3173	11-2443-B
19	2.25	1	LID LOCK ASSY, 31.00 LG	B18019	B18019
20	13.82	1	V-RING SEAL	M-2938	-
21	8.75	1	MACHINED HUB SEAL	B12736	B12736
22	19.16	1	REAR HUB LINER	B12817	B12817
23	56.24	1	CAST MOTOR MOUNT ONE SIDED DRAIN SLOTS	M-7475	13-6541-B
24	0.11	1	M-LOK ASSY, .75 HEX, .8125 BODY	B22467	B22467
25	0.72	4	M-LOK ASSY, 1.25 HEX, M5	B18015	B18015
26	0.01	4	M-LOK SEAL	M-6298	13-5394-A
27	0.11	1	QUICK RELEASE PIN	MH-1511	-
28	0.11	3	PIN WITH RETAINER SNAP; 3/8 OD	M-3087	-
29	0.05	1	WEDGE WASHER	M-3067	11-2286-A
30	0.01	1	RUBBER WASHER	M-3068	11-2287-A
31	0.080	2	SCREW, SHC, SHOULDER, .50 DIA. X .50 LG, .375-16UNC X .625 LG, ASTM A574	MH-2351	-
32	0.025	2	WASHER, BELLEVILLE, .500 X 1.500 X .112 THK, STEEL	M-180771	-
33	0.009	2	SHOULDER BOLT 3/8" DIA. X 1 1/2" LG	MH-1716	-
34	0.011	8	WASHER, FLAT, .312 TYPE A, WIDE (USS) STEEL	MH-1001	-
35	0.013	2	NUT, HEX, NYLON LOCK, .312-18UNC, STEEL, GR.8	MH-1560	-
36	0.039	6	SCR, FHC, .375-16UNC X 1.00 LG, STEEL	MH-1645	-
37	.038	4	SCR, HHC, .375-16UNC X .875 LG, GR.5	MH-1238	-
38	.041	18	SCR, HHC, .375-16UNC X .750 LG, GR.5	MH-1237	-
39	0.006	22	WASHER, LOCK, SPLIT, MEDIUM, .375, STEEL	MH-1011	-
40	0.007	4	WASHER, FLAT, .375 TYPE A, STANDARD (SAE) STEEL	MH-1386	-
41	.096	18	WASHER, FENDER, .500 X 1.75 OD, .125 THICK, STEEL, ZINC	MH-2436	-
42	0.04	4	T-NUT, .38-16NC THREAD	B17877	B17877
43	0.031	3	SCR, SET, CUP POINT, .313-18UNC X 1.50 LG, STEEL, BLACK OXIDE	MH-2144	-
44	0.004	3	WASHER, LOCK, SPLIT, MEDIUM, .312, STEEL	MH-1010	-
45	0.01	3	NUT, HEX, FINISHED, .312-18UNC, STEEL GR.5	MH-1028	-
46	0.353	4	SCR, SET, CUP POINT, .750-10UNC X 3.00 LG, STEEL ASME B18.3, ASTM F912, BLACK OXIDE	MH-2732	-
47	0.418	6	SCR, HHC, .750-10UNC X 2.25 LG, GR.5	MH-1330	-
48	0.041	10	WASHER, LOCK, SPLIT, MEDIUM, .750, STEEL	MH-1015	-
49	0.117	4	NUT, HEX, FINISHED, .750-10UNC, STEEL GR.5	MH-1033	-
50	4.89	1	15-30 HP MOTOR SPACER RING	SEE TABLE	-
51	5.93	1	CONTROL CAGE	SEE TABLE	-
52	3.72	1	E BLADE, SET OF 8	SEE TABLE	-
53	33.52	1	E-WHEEL	SEE TABLE	-
54	-	1	MOTOR	SEE TABLE	-
55	17.43	2	M4 ENDLINER, TOP	SEE TABLE	-
56	23.56	2	M4 ENDLINER, BOTTOM	SEE TABLE	-

BLAST TECHNOLOGIES

DESCRIPTION: M4 TWISTLOK e-WHEEL ASSEMBLY

DATE: 06/22/2020

REV: A

SIZE: D

DWG NO: B1044104

SCALE: 1:10

EST WT: 1482.06#

SHEET 1 OF 1