

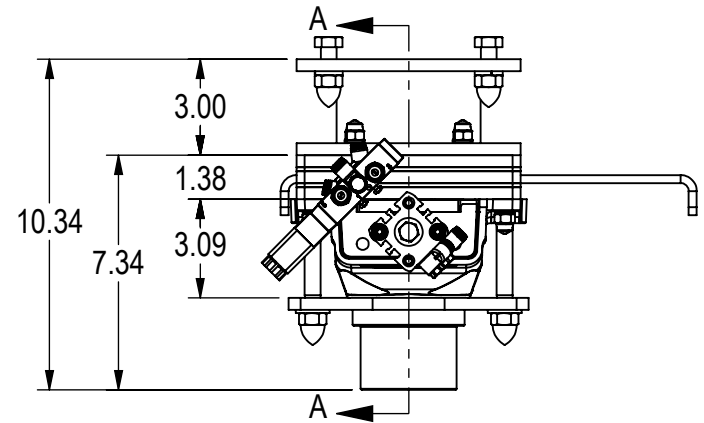

ITEM NO.	WEIGHT	M-3731-024/QTY.	M-3731-120/QTY.	DESCRIPTION	PartNo	Number
1	20.5	1	1	Abrasive Valve AVM	M-3712	12-2987-B
2	17.3	1	1	Magnetic Sealed Slide Gate	M-3716	12-2990-B
3	9.56	1	1	Inlet Spacer	M-416709	11-2448-B
4	0.11	4	4	HHCS, 1/2"-13NC X 1 1/4" LG	MH-1276	-
5	0.01	4	4	WASHER, LOCK, 1/2"	MH-1013	-
6	0.06	4	4	NUT, HIGH CROWN ACORN, 1/2"-13NC, ZINC	MH-1512	-
7	2.22	1	-	AVM SOLENOID VALVE PNEUMATIC KIT	M-3734-024	12-3004-B
8	2.22	-	1	AVM SOLENOID VALVE PNEUMATIC KIT	M-3734-120	12-3004-B

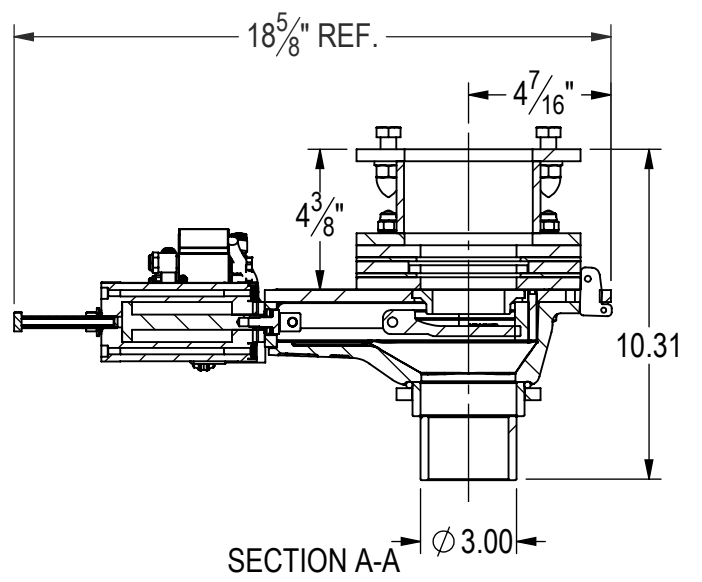

**NOTE:
ASSEMBLY DRAWING FOR REFERENCE,
VERIFY PART NUMBERS WITH FACTORY
PRIOR TO ORDERING**

PROPRIETARY AND CONFIDENTIAL THE INFORMATION CONTAINED IN THIS DRAWING IS THE SOLE PROPERTY OF BCT. ANY REPRODUCTION IN PART OR AS A WHOLE WITHOUT THE WRITTEN PERMISSION OF BCT IS PROHIBITED.	UNLESS OTHERWISE NOTED				
	DIMENSIONS ARE IN INCHES TOLERANCES: ANGULAR: ± 1° TWO PLACE DECIMAL ± 0.060" THREE PLACE DECIMAL ± 0.030"				
	MODELED BY	DATE	DESCRIPTION ABRASIVE VALVE WITH ACCESSORIES		
	DRAWN BY Lee	DATE 01/20/2012			
		SIMILAR TO	SIZE B	DWG NO 12-3000-B	REV E
DO NOT SCALE DRAWING		SCALE: 1:6	EST WT: 50.35#	SHEET 1 OF 1	