

4-WHEEL ROLL CONVEYOR BLAST MACHINE

Model # R4 - 18x12

FEATURES

- 50 LB/FT CAPACITY
- 4 - 10 HP DIRECT DRIVE BLAST WHEELS
- SHOT ADDER
- FLOOR-MOUNTED SEPARATOR
- OPTIONAL PARTS BLOWOFF
- OPTIONAL ROTARY SCREEN
- 460VAC, 3 PHASE
- SAFETY INTERLOCKS
- PLC AND HMI CONTROLS
- 1 YEAR MACHINE WARRANTY
- CONTINUOUS PRODUCTION
- ABRASIVE RESISTANT LINED BLAST CHAMBER
- SLIDING BLAST CABINET MAINTENANCE DOOR

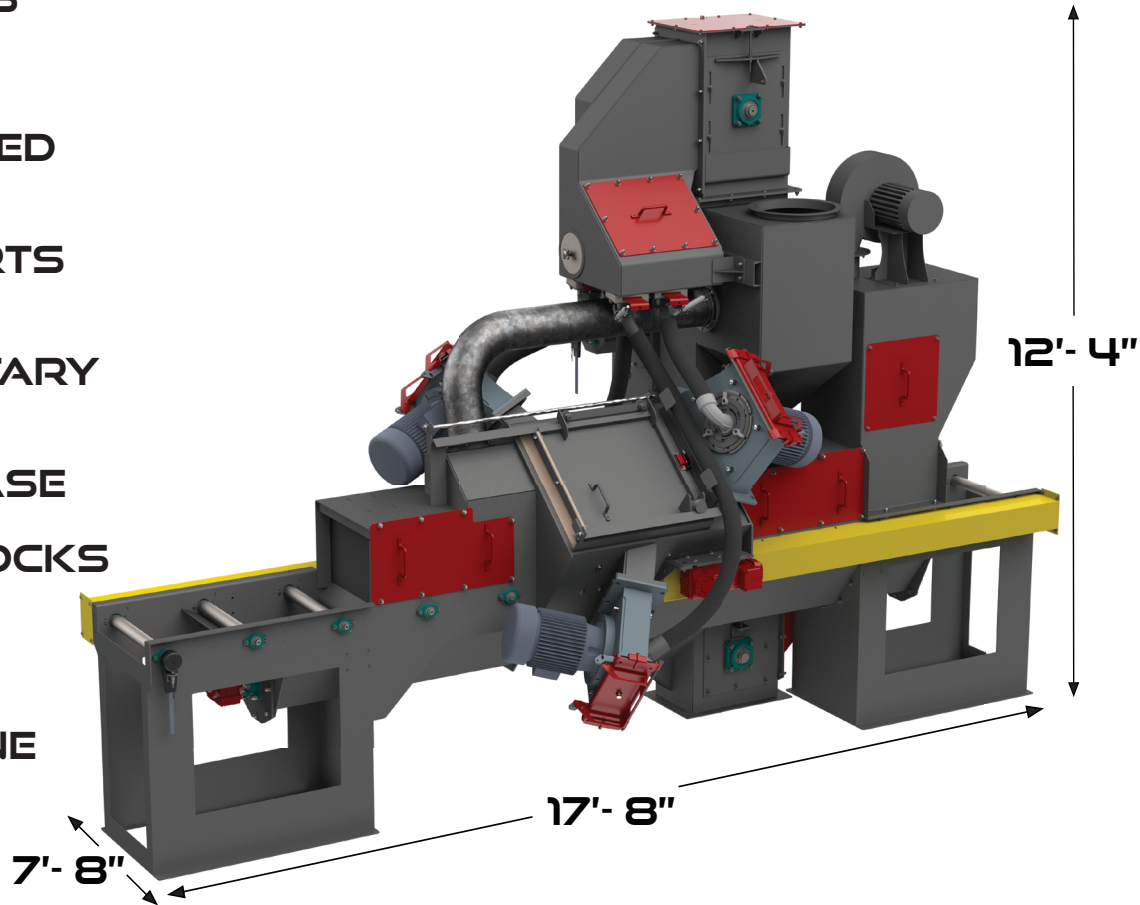

TECHNOLOGY. SERVICE. SOLUTIONS.

Phone: 877.355.7577 • Fax: 262.785.1066 • 6682 W Greenfield Ave, Suite 103 • West Allis, WI 53214 • www.bct-us.com



BLAST CLEANING TECHNOLOGIES



TECHNICAL DATA

4-WHEEL ROLL CONVEYOR BLAST MACHINE

Model # R4 - 18x12

CENTRIFUGAL BLAST WHEEL

Wheel: Four (4) Blast Wheels, 3600 RPM, 14" or 15" direct drive. Precision balanced internal components
Blade Style: Exclusive RIM-LOC design ensures easy replacement of long life, abrasive resistant, alloy blades
Control Cage: Dial Type cage
Wheel Housing: ¼" Steel fabricated blast housing with replaceable alloy liner package

CABINET CONSTRUCTION

Cabinet: Fabricated from 3/8" steel plate. Fully welded abrasion resistant (AR) steel
Lining: Blast chamber is lined with cast alloy liners in-line with blast pattern
Seals: Inlet and exit gum rubber seals
Cabinet Ventilation: Air inlet and outlet positioned to provide dust evacuation of blasting zone

POWER AND AIR REQUIREMENTS

Electric Supply: 460 VAC, 3 Phase, 60 Hz. Others available by request
Controls: NEMA 12 rated electrical enclosure, 24VDC PLC and HMI controls, IEC motor starters, blast wheel amperages monitors, hour meter, abrasive blast and post blast timers, and abrasive adder
Electric Motors: Totally enclosed, fan cooled (TEFC)
Blast Wheels: Four (4) 15HP, 3600 RPM
Elevator Drive: 2HP, 1800 RPM
Belt Drive: 1/3HP, 2 RPM
Air Requirement: 90 PSI, 10CFM Clean, dry, regulated compressed air

ABRASIVE RECLAIM SYSTEM

Abrasive Screening: Manganese Shed Plates guard auger in cabinet
Abrasive Control: Fully enclosed adjustable butterfly valve
Abrasive Required: 1800 pounds for initial start-up
Elevator: Dust-tight, centrifugal discharge belt and bucket elevator, removable service covers and take-up screws
Separator: 20" airwash separator. Adjustable abrasive spreader and refuse gate provide a thorough air washing of abrasive for maximum contaminate removal.

SAFETY AND STRUCTURE

Safety: Blast wheels operate only when rear door is closed, chamber seals prevent stray abrasive, abrasive valves operate only during blast cycle. Emergency stop on control panel and safety reverse on cabinet side
Shipping Weight: 9600 pounds
Machine Dimensions: 7'-8" Width x 17'-8" Length x 12'-4" Height

TECHNOLOGY. SERVICE. SOLUTIONS.

Phone: 877.355.7577 • Fax: 262.785.1066 • 6682 W Greenfield Ave, Suite 103 • West Allis, WI 53214 • www.bct-us.com