

616 DUST COLLECTOR 6-CARTRIDGE SYSTEM

Model # 616

FEATURES

- REVERSE PULSE
- 6 CARTRIDGES
- STANDARD MAGNEHELIC GAUGE
- CONTINUOUS CLEANING
- 115VAC, 1 PHASE OR 460VAC, 3 PHASE
- 1 YEAR MACHINE WARRANTY
- SMALL OPERATING FOOTPRINT
- EASY CLEAN OUT
- INDOOR OR OUTDOOR USE
- AFTER FILTER OPTIONS AVAILABLE
- 600 OR 800 CFM CAPACITY

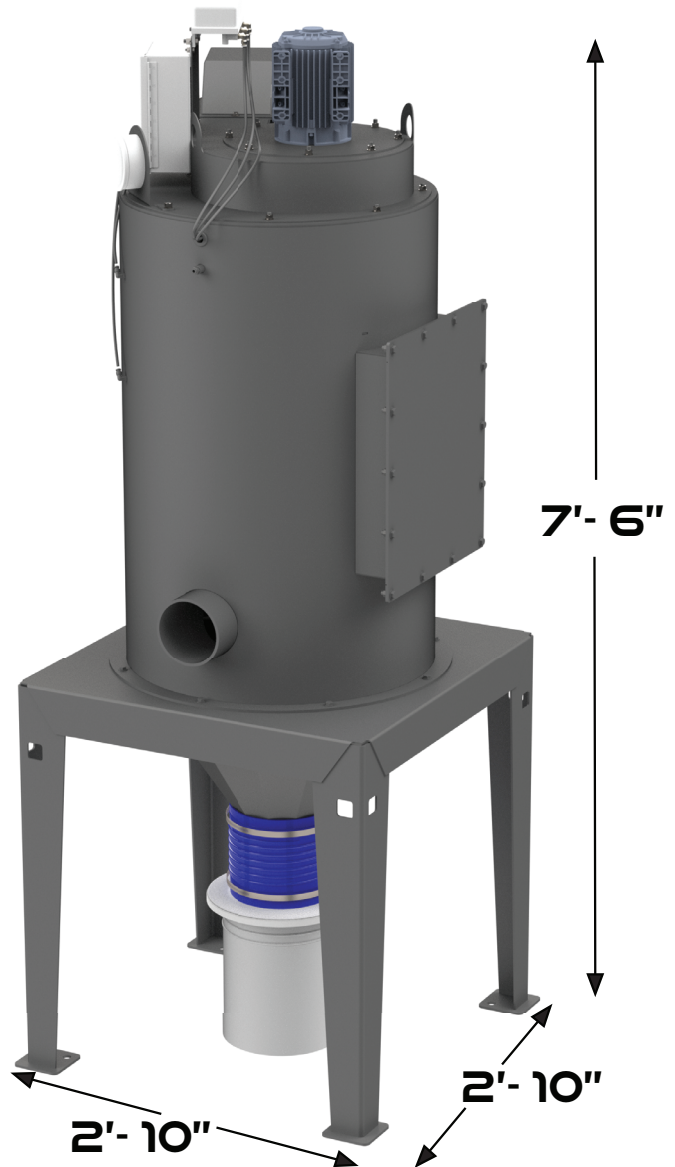

TECHNOLOGY. SERVICE. SOLUTIONS.

Phone: 877.355.7577 • Fax: 262.785.1066 • 6682 W Greenfield Ave, Suite 103 • West Allis, WI 53214 • www.bct-us.com



BLAST CLEANING TECHNOLOGIES



TECHNICAL DATA

616 DUST COLLECTOR 6-CARTRIDGE SYSTEM

Model # 616

CFM

Efficiency: 99.70% at .5 micron

CONSTRUCTION

Unit: Fully assembled and prewired, 10 and 12-gauge construction. Access Door for easy filter inspection and replacement
Lifting Eyes: Two lifting eyes for easy transport and placement
Environment: Weatherproof enclosures and motors

POWER AND AIR REQUIREMENTS

Electric Supply: 115 VAC, 1 Phase, 60 Hz or 460 VAC, 3 Phase, 60 Hz. Others available by request
Controls: NEMA 12 rated electrical enclosure, standard magnehelic gauge (Optional photohelic gauge)
Electric Motors: Totally enclosed, fan cooled (TEFC)
Dust Collector Fan: Motor HP to match application
Air Requirement: 3CFM of clean, dry, compressed air @ 80/90 PSI (1/4" NPT connection)

REFUSE COLLECTION

Cartridges: Six (6) 8" x 16", 80-20 media 150 pleat cartridges with 396 ft² of media
Self Cleaning: Automatic, reverse-pulse cleaning system for long cartridge life Standard
Containment: 5-gallon dust bin provided for easy removal of dust
Container Removal: Single break-over latch to easily remove dust bin

SAFETY AND STRUCTURE

Safety: Exhaust deflector provided to direct air up or down
After Filter: Optional HEPA Filter 99.97% at 0.3 microns
Shipping Weight: 585 pounds
Machine Dimensions: 2'-10" Width x 2'-10" Length x 7'-6" Height

TECHNOLOGY. SERVICE. SOLUTIONS.

Phone: 877.355.7577 · Fax: 262.785.1066 · 6682 W Greenfield Ave, Suite 103 · West Allis, WI 53214 · www.bct-us.com